

## 13 Contact

If you have any technical problems concerning our products, please contact Solplanet service.

### Service Contact:

**Hotline: +48 134 926 109 ( Europe )**

You can submit your claims online by visiting website:

<https://solplanet.net/installer-area#claims>

or by sending email:

[service.eu@solplanet.net](mailto:service.eu@solplanet.net)

You will get response within 24 hours

### **AISWEI Industrial (Shanghai) Co., Ltd.**

Add.: Room A-1327, No.188 Building, Yesheng Road, Lingang Area,China (Shanghai) Pilot Free Trade Zone.

### **AISWEI New Energy Technology (Jiangsu) Co., Ltd.**

Headquarters add.: Building 9, No.198 Xiangyang Road, Suzhou 215011, China

### **AISWEI New Energy Technology (Yangzhong) Co., Ltd.**

Factory add.: No.588 Gangxing Road, Yangzhong Jiangsu, China



## EV Charger- User Manual



## **Thank you for choosing the Solplanet EV charger.**

The Solplanet EV charger is an AC power charging station, it supplies AC power to charge electric vehicles.

The EV charger is suitable for outdoor and indoor use such as garages, carports underground car parks, apartment blocks, hotel parking lots and other areas where an EV charger may be suitable.

The EV charger, except the plug and play version, can be operated with an RFID card or via our EV charger APP.

This manual describes the installation, commissioning, and maintenance of the following Solplanet EV chargers: SOL7.4EV Series, SOL11EV Series, SOL22EV Series.

Please read and follow the instructions in this manual carefully.

**Content**

1	About this document .....	3
2	Safety information .....	4
3	Scope of Delivery .....	5
4	Product overview.....	6
4.1	Product overview .....	6
4.2	LED signals.....	7
5	Mounting.....	7
5.1	Requirements for mounting.....	7
5.2	Mounting of the EV Charger .....	10
6	Electrical connection .....	11
6.1	Power supply connection.....	11
6.2	Connecting the EV Charger .....	12
7	Communication .....	12
8	Commissioning & Operation .....	13
9	Maintenance.....	14
10	Technical specifications.....	15
11	Troubleshooting.....	18
12	Recycling and disposal .....	19
13	Contact .....	20

## 1 About this document

This document, intended for qualified persons and qualified electricians, describes the activities relating to the installation, commissioning, operation and maintenance of the Solplanet EV charger (Charger.)

The contents of this document apply to the following charger models:

- SOL7.4EV-O
- SOL7.4EV-R
- SOL7.4EV-WR
- SOL7.4EVS-O
- SOL7.4EVS-R
- SOL7.4EVS-WR
- SOL11EV-O
- SOL11EV-R
- SOL11EV-WR
- SOL11EVS-O
- SOL11EVS-R
- SOL11EVS-WR
- SOL22EV-O
- SOL22EV-R
- SOL22EV-WR
- SOL22EVS-O
- SOL22EVS-R
- SOL22EVS-WR

The models listed above are equipped with a variety of interfaces, please check the technical specifications in section 10 to confirm the interfaces that are available on the charger.

Please note that a WiFi connection is mandatory for enabling advanced features that are available on the SOLxxEVx-WR charger. The charger can then be used to charge an electric vehicle (EV) without the App after the set-up and configuration has been completed.

Please note that a point to point connection between the charger and a smart mobile device is not possible.

## 2 Safety information

Before using or maintaining this product, it is important to read the following safety instructions. Failure to follow and implement all the specified instructions and procedures, will invalidate the warranty and as such Solplanet will not be liable for any claims for compensation.

### DANGER

- Do not open the charger.
- Do not use the charger if it is damaged.
- Do not use an extension lead on the charging cable.
- Do not touch or insert foreign objects into plugs.
- Do not install the charger near flammable, explosive, or combustible materials.

### WARNING







- All work on the equipment must only be carried out by qualified personnel who have read and fully understood all safety information and installation requirements contained in this manual.
- The charger must be out of reach from children.
- EV charger must be connected to a protective earth conductor.
- The electrical installation must comply with all local applicable safety requirements, standards and guidelines.
- No modifications must be made to the EV charger.
- Components should not be changed or replaced by the end-user or unqualified personnel.

Symbols on type label

Symbol	Explanation
	Risk of danger, warning and caution Safety information important for human safety. Failure to observe the safety information in this manual may result in injury or death.
	Beware of high voltage and operating current. The EV charger operates at high voltage and current. Work on the EV charger must only be carried out by skilled and authorized electricians.
	Certified safety The product is TUV-tested and complies with the requirements of the EU Equipment and Product Safety Act.
	CE mark. The EV charger complies with the requirements of the applicable EC guidelines.
	Do not dispose of the EV charger with household waste. For more information on disposal, please refer to Section 11 "Recycling and disposal".
	Refer to the manual accompanying the EV charger.

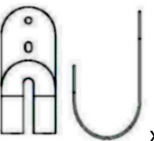
### 3 Scope of Delivery

Check the product packaging for any external visible damage and ensure that all items in the table below have been included. Contact your distributor if the accessories delivered are incomplete or the EV charger or accessories have been damaged.

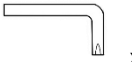
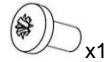
RFID card	x3(Optional)	User manual	x1
APP function manual	x1(WIFI Version)		
Solplanet EV charger	 x1	Mounting plate(A)-fixed on the charger	 x1
Cable holder	 x1	Mounting plate(B)-wall bracket	 x1
Screws for Mounting plate(A)	 x4	Screws for Mounting plate(B) and cable holder	 x6
Screw-driver for anti-theft screw	 x1	Anti-theft screw	 x1

### 4 Product overview

#### 4.1 Product overview

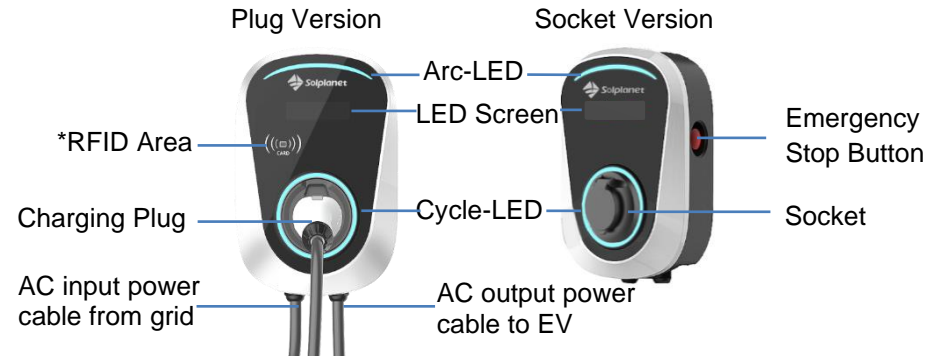

**\*RFID Area:** This function is applicable to the following models: SOL7.4EV-R, SOL7.4EV-WR, SOL7.4EVS-R, SOL7.4EVS-WR, SOL11EV-R, SOL11EV-WR, SOL11EVS-R, SOL11EVS-WR, SOL22EV-R, SOL22EV-WR, SOL22EVS-R, SOL22EVS-WR

**⚠ WARNING**

**Do not change or modify the AC input and AC output connectors or glands that are supplied with the EV charger.**

## 4.2 LED signals

The LEDs indicate the operating status of the EV charger.

### Explanation of the different light signals

Explanation	Arc-LED	Cycle-LED
<b>Emergency stop</b>	Red	Red
<b>Standby</b>	Blue (flashing)	Blue (flashing)
<b>Ready to charge</b>	Green	Green
<b>Charging</b>	Green	Green (flashing)
<b>End of charging</b>	Green	Blue
<b>RCD over limit</b>	Red (flashing)	Red (flashing)
<b>Over / Under voltage</b>	Red	Blue
<b>Over current protection</b>	Red	Green
<b>Over temperature protection</b>	Red (flashing)	Blue (flashing)
<b>Hardware failure</b>	Red	Green (flashing)
<b>Power off</b>	No Light	No Light

## 5 Mounting

### 5.1 Requirements for mounting

#### WARNING

- Requirements for mounting location:
- Danger to life due to fire or explosion.
- Despite careful construction, if installed incorrectly or mounted in unsuitable locations, electrical devices can cause fires. This can result in death or serious injury.
- Do not mount the EV charger in areas containing highly flammable materials or gases.
- Do not mount the charger in potentially explosive atmospheres.

The EV charger must not be directly exposed to sunlight.

The surface for mounting of the EV charger must be made of a non-flammable material.

EV charger can be mounted on a pole for our door use.

The location must offer sufficient air ventilation.

The installation surface area requires at least 237 mm x 343 mm.

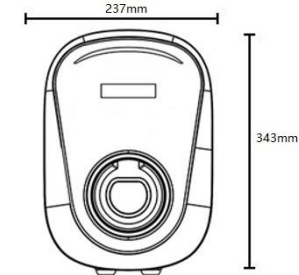

A solid, flat support surface, e.g., concrete or masonry, must be available for mounting.

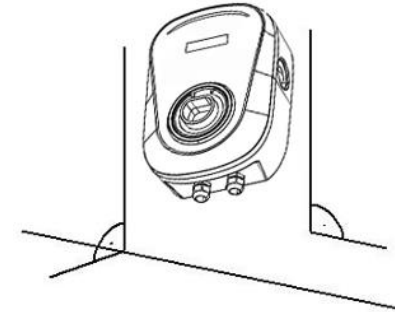

A minimum clearance of 20 cm from other equipment or objects must be kept.

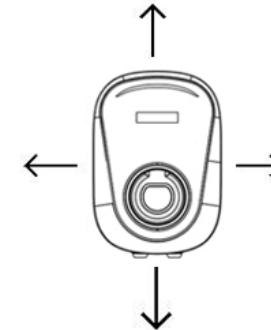

The installation height is between 140 and 160 cm (from the floor to the bottom of the EV charger housing).

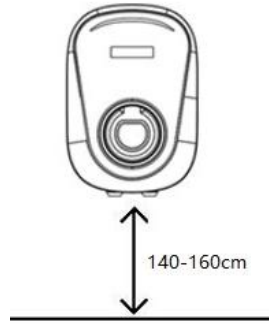

The installation location must be freely accessible.

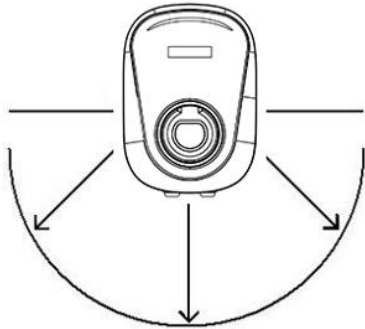

The mounting location must be selected so that the EV Charger and the vehicle can be connected with the charging cable without exerting undue stress on the charging cable.

## 5.2 Mounting of the EV Charger

- 1) Using the mounting plate (B) as a template to determine the position of the holes, drill four holes at a depth 50mm with an electric drill using an  $\phi 8$ mm drill bit. Insert the expansion plugs in the drilled holes gently with a hammer. Attach the mounting plate (B) on the wall and tighten the screws.

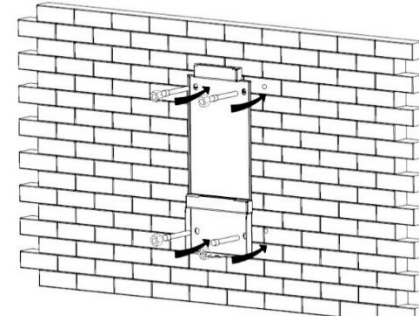

- 2) Use an appropriately sized screwdriver to fix mounting plate (A) to the EV charger.

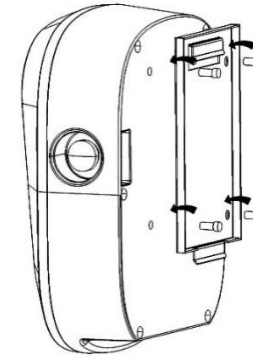

3) Carefully hang the EV charger to the mounting plate.

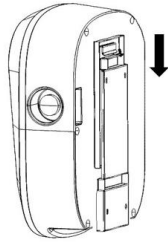

4) Insert and tighten the anti-theft screw to protect the charger from theft.



## 6 Electrical connection

### 6.1 Power supply connection



**The charging current must never be set higher than the line fuse itself.**

If the charger is to be operated with an output of 7 kW and 22 kW, it must be protected with an 40 A over current protection device (such as fuse), and 11kW with a 20A over current protection device (such as fuse).

Ensure the current carrying capacity of the AC cable into the EV charger is greater than the current rating of the over current protection device.

Ensure the installation site has a connection to the utility grid. If unsure, please contact your electrical contractor.

Connect the AC cables as per the image below, ensure the cables are connected to the

corresponding terminals that are labeled L, N and PE. An isolating device, between the charger and the AC power supply, such as a fuse, circuit breaker, residual current device should also be installed if mandated by the local electrical regulations.



The product provide disconnection means and a residual current monitoring for detecting 6 mA direct residual current. In order to guarantee safety in accordance with IEC 61851-1 that RCD Type A and appropriate equipment that ensures the disconnection of the supply in case of DC fault current above 6 mA. The additional overcurrent protection and approved RCD Type A need to be provided in the installation as well.

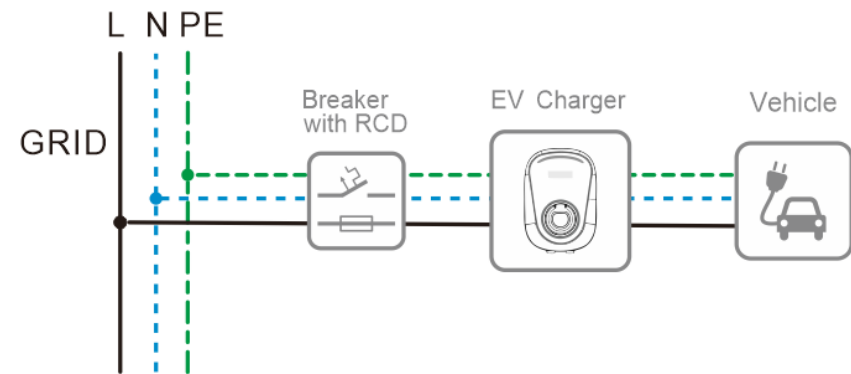

### 6.2 Connecting the EV Charger

- The EV must be stationary during the charging process.
- The charging cable and the charging connector must not be driven over.
- The charging cable must not be strained, squeezed, or bent.
- The charging cable must be stored securely.

## 7 Communication

The charger of WiFi version is set to 'Plug & Play Mode' by default, users can charge EV's without authorization.

For the SOLxxEVx-WR charger models, users can disable 'Plug & Play mode' via the Solplanet Sol EVPower APP. Please refer to the APP manual for the information.

For the SOLxxEVx-R (RFID) charge models, users can enable charging by using the supplied IC card(s).



## 8 Commissioning & Operation

### Plug and Play mode enabled (Default)

1. Ensure that the emergency stop button is released
2. Energize the charger, and wait for approximately 10 seconds for the device to complete its self-test
3. Arc-LED and cycle-LED will flash blue, this indicates the EV Charger is in standby state
4. Charging can begin by connecting the charger to the EV. For SOLxxEVx-R model, users must first swipe the IC card before every charge, while for SOLxxEVx-WR models, users can swipe the IC card or operate on APP.
5. The EV charger starts working normally when the arc-LED is green and cycle-LED is green(flashing).

### Plug and Play mode disabled

Plug and play mode can be disabled on the SOLxxEVx-WR charger models via the App, please refer to the App manual for further information.

### Additional features such as:

- Registering a Solplanet account
- Connecting the charger to a WiFi network
- Adding a charger(s) to an registered account
- Sharing a charger(s) to other registered accounts
- Monitoring the status of the charger(s)
- Set-up of the following functions:
  - Reserve charge
  - Load balancing

Can be carried out via the App and are available only on the SOLxxEVx-WR models. Please refer to the App manual for further information.

## 9 Maintenance

EV charger must only be cleaned by using a dry cloth.



The EV charger must be regularly inspected for visual damage.



The charging cable must be regularly checked for any damage or deterioration.



## 10 Technical specifications

Technical Datasheet-7.4kW		SOL7.4EV-O	SOL7.4EV-R	SOL7.4EV-WR	SOL7.4EVS-O	SOL7.4EVS-R	SOL7.4EVS-WR
Input & Output	Rate Voltage	230 V AC					
	Input Frequency	50Hz / 60Hz					
	Max Output Power	7.4 kW					
	Max Output Current	32 A					
	Standby Power	2 W					
Internal RCD	DC 6mA						
Charging Interface	IEC62196-2, ype 2 plug			IEC62196-2, ype 2 socket			
Cable Length	5m			-			
User interface& Control	Network Interface	-	-	WIFI	-	-	WIFI
	RFID	-	•	•	-	•	•
	Status Indication	Halo RGB LED					
	LED Display Screen	•					
	APP	-	-	•	-	-	•
Working Environment	Protection Level	IP55(Storage), IP54(Mated with vehicle)					
	Operating Temperature	-30°C to 50°C					
	Storage Temperature	-40°C to 70°C					
	Relative Humidity	5% to 95% non-condensing					
	Altitude	Up to 2000 m					
	Cooling	Natural Cooling					
Mechanical	Mounting	Wall					
	Product Dimensions (W/H/D)	237x343x115 mm					
	Product Net Weight	6 kg			3 kg		
Safety	DC Leakage Protection	•					
	Over Current Protection	•					
	Over Voltage Protection	•					
	Under Voltage Protection	•					
	Over Temperature Protection	•					
	Ground Protection	•					
	Surge Protection	•					
	Emergency Stop Button	•					
	Regulation	CE, TUV / EN 61851-1& EN 61851-22					

Technical Datasheet-11kW		SOL11EV-O	SOL11EV-R	SOL11EV-WR	SOL11EVS-O	SOL11EVS-R	SOL11EVS-WR
Input & Output	Rate Voltage	400 V AC					
	Input Frequency	50Hz / 60Hz					
	Max Output Power	11 kW					
	Max Output Current	16 A					
	Standby Power	2 W					
	Internal RCD	Type A and DC 6mA RCD function					
	Charging Interface	IEC62196-2, Type 2 plug			IEC62196-2, Type 2 socket		
	Cable Length	5m			-		
User interface& Control	Network Interface	-	-	WIFI	-	-	WIFI
	RFID	-	•	•	-	•	•
	Status Indication	Halo RGB LED					
	LED Display Screen	•					
	APP	-	-	•	-	-	•
Working Environment	Protection Level	IP55(Storage), IP54(Mated with vehicle)					
	Operating Temperature	-30°C to 50°C					
	Storage Temperature	-40°C to 70°C					
	Relative Humidity	5% to 95% non-condensing					
	Altitude	Up to 2000 m					
	Cooling	Natural Cooling					
Mechanical	Mounting	Wall					
	Product Dimensions (W/H/D)	237x343x115 mm					
	Product Net Weight	6 kg			3 kg		
Safety	DC Leakage Protection	•					
	Over Current Protection	•					
	Over Voltage Protection	•					
	Under Voltage Protection	•					
	Over Temperature Protection	•					
	Ground Protection	•					
	Surge Protection	•					
	Emergency Stop Button	•					
	Regulation	CE, TUV / EN 61851-1& EN 61851-22					

Technical Datasheet-22kW		SOL22EV-O	SOL22EV-R	SOL22EV-WR	SOL22EVS-O	SOL22EVS-R	SOL22EVS-WR
Input & Output	Rate Voltage	400 V AC					
	Input Frequency	50Hz / 60Hz					
	Max Output Power	22 kW					
	Max Output Current	32 A					
	Standby Power	2 W					
	Internal RCD	DC 6mA					
	Charging Interface	IEC62196-2, Type 2 plug			IEC62196-2, Type 2 socket		
Cable Length	5m			-			
User Interface & Control	Network Interface	-	-	WIFI	-	-	WIFI
	RFID	-	•	•	-	•	•
	Status Indication	Halo RGB LED					
	LED Display Screen	•					
	APP	-	-	•	-	-	•
Working Environment	Protection Level	IP55(Storage), IP54(Mated with vehicle)					
	Operating Temperature	-30°C to 50°C					
	Storage Temperature	-40°C to 70°C					
	Relative Humidity	5% to 95% non-condensing					
	Altitude	Up to 2000 m					
	Cooling	Natural Cooling					
Mechanical	Mounting	Wall					
	Product Dimensions (W/H/D)	237x343x115 mm					
	Product Net Weight	6 kg			3 kg		
Safety	DC Leakage Protection	•					
	Over Current Protection	•					
	Over Voltage Protection	•					
	Under Voltage Protection	•					
	Over Temperature Protection	•					
	Ground Protection	•					
	Surge Protection	•					
	Emergency Stop Button	•					
Regulation	CE, TUV / EN 61851-1& EN 61851-22						

• standard features   ○ optional features   - not available

## 11 Troubleshooting

Error messages are displayed in the LED screen.

Error message	Explanation	Solution
No light	No power or incorrect connection or EV charger fault.	Check if the breaker is turned on and cables are connected securely and correctly.
ES	The emergency stop switch is pressed.	Release the emergency stop switch
OC	EV charger detects over current.	Contact the service provider if it occurs frequently.
OV or UV	The supply voltage is too high or too low.	Check that the supply voltage is within 95 to 275V.
OT	The internal temperature of the EV charger is too high.	Check whether the ambient temperature around the inverter is too high or whether it is exposed to direct sunlight. Please stop charging for a few hours and wait for the temperature of the EV charger to cool down. Contact the service provider if it occurs frequently.
LC or ERR 16	EV charger detects leakage current.	Check the EV charger cable and housing for damage and contact the service provider.
GND	EV charger detects bad grounding.	Contact the service provider and request a check of the earthing of the EV charger.
CP or ERR 14	EV charger detects charging CP signal error.	Please refer to sections 6 and 7 for charging. Contact the service provider if it still occurs.
ERR 02	EV charger detected electric lock failure.	Re-powering off the EV charger, if the error occurs again, please contact your service provider to check the electric lock.
ERR 04	WIFI module failure	Contact the service provider.
ERR 06	RFID module failure	Contact the service provider
ERR 08, ERR 11, ERR 12 or ERR 13	EV charger control board failure	Contact the service provider
ERR 15	EV charger detected relay failure.	Request a professional to check the voltage between the neutral line and ground line and contact the service provider.

## 12 Recycling and disposal

- This device is used to charge electric vehicles and is subject to the EU directive 2012/19 / EU on waste electrical and electronic equipment (WEEE).
- Disposal must be according to national and regional Regulations for electrical and electronic equipment respectively.
- Old devices and batteries must not be disposed of with household waste or bulky waste. Before the device being disposed of should it be rendered inoperable.
- Dispose of the packaging material in the region's usual collection container for cardboard, paper, and plastics.

